

B

BREEDER FEEDING



PULLET FEEDING (0-18 WEEKS)

Spin feeders are a simple, effective and economical method of providing broiler breeder pullets (male and female) with an evenly distributed supply of feed directly on the ground. The result is birds with very uniform body weight and only a very reduced work load for the producer.

Function

Spin feeders with hoppers are installed along the center of the rearing house, either suspended from the ceiling or standing on supports. All spinners start dispensing feed simultaneously. The specially developed spin head from LANDMECO ensures that feed is evenly distributed over the entire circular spread area as determined by the rotation speed.

Manual control

The spin feeder can be operated manually by a variator gear motor.

Automatic controls

All spin feeders can also be operated via a central control unit which is set according to the age of the birds:

- ❶ The number of feedings required
- ❷ The duration of feeding
- ❸ The area to be covered



EXAMPLE OF SPREAD AREA

Capacity 1700 chickens
Spread area 113 m² (1216.32 ft²)
Diameter 12 m (39.3701 ft)

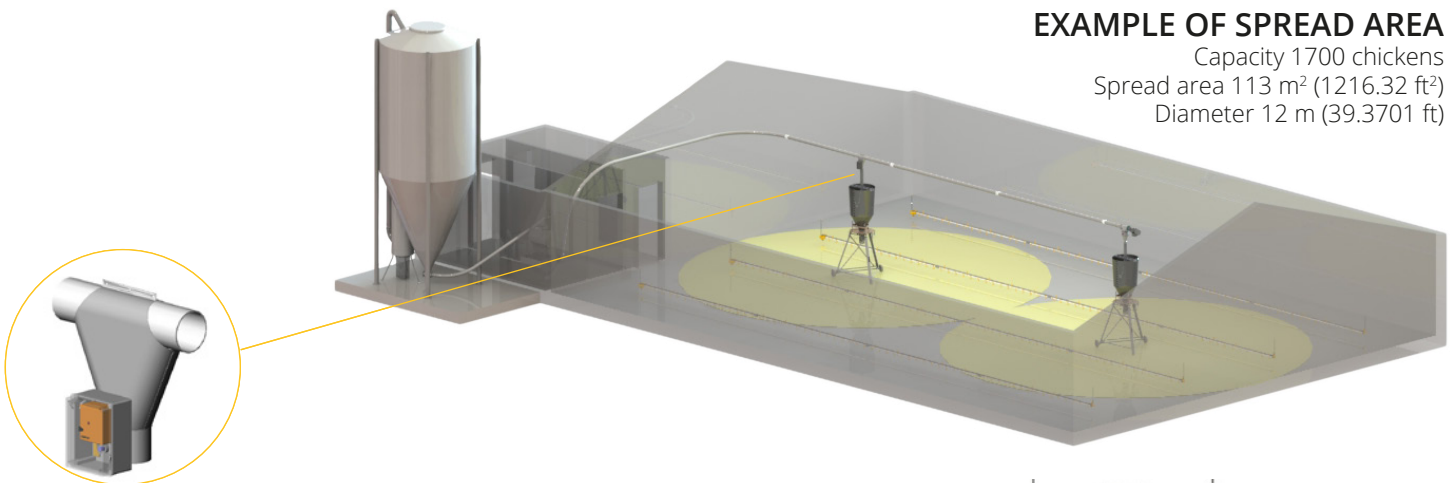

MALE FEEDING

High reliability

The male feeding system is based on a few thoroughly tested standard components, thus ensuring high reliability and low maintenance costs. The system can be winched off the ground.

Rapid feed distribution

The direct drive and vertical return wheels allow the chain to run at a very high speed. This ensures a rapid feed distribution and the simultaneous feeding of all cocks.

Automatic controls

Male feeding is activated by a time switch on the hen feeding system so that all birds can be fed simultaneously or separately as required.

LANDMECO also offers separate controls for male feeding.

Transparent feed hopper

LANDMECO's plastic feed hopper is light, quick and easy to mount and dismount and consists only of a few parts. The transparency in the tank provides optimal opportunities for good management and good hygiene.



FEMALE FEEDING

The feeding system for breeding stock is based on LANDMECO's well-known chain feeding system and has two feed inlets for each circuit. The trough is raised and lowered automatically so that all birds are fed simultaneously as described in the following:

① Raised position

In this position, hoppers are filled with the required feed quantity. This is regulated by the feed weigher. Just before feeding time, the chains are started so that they become filled throughout the system. When the chains have completed the circuit, the trough is lowered automatically to the required feeding height.

② Lowered position

The hens eat the feed in the trough, and the process is repeated until the feed dose has been used. After feeding is completed, the trough is raised again.

Experience has clearly shown that the stress levels of feed-rationed birds and the number of eggs laid on the ground are considerably reduced by the use of this feeding system.

Steel hoppers or plastic hoppers?

When using the plastic hoppers, these are hoisted and lowered together with the trough. When using the steel hoppers, which are suspended from the ceiling, it is only the trough which is hoisted and lowered.

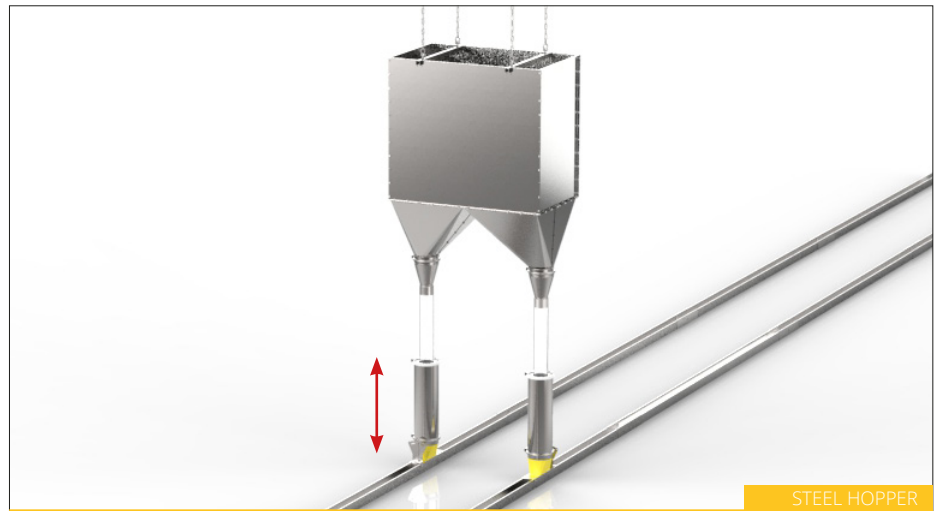

STEEL HOPPER



PLASTIC HOPPER

GRILL & ROLLER BAR

LANDMECO provides 2 types of grill: Grill for standard trough, and grill for breeder trough with anti-sitting top.

The grill comes with a standard distance of 44 mm (1.7323 inch) but is also offered with other distances on request.

As an alternative, LANDMECO provides the roller bar on top of the feeding trough for separate sex feeding. The system treats the hens gently as the round bar rolls against the hens' heads. At the same time, males are prevented from eating as their heads are larger.

Clearance between roller bar and trough edge can be easily adjusted to suit hen head size.

The roller bar is made of aluminum and is therefore very light. Roller bars are available in lengths of 2.5 meters. (8.2021 ft).

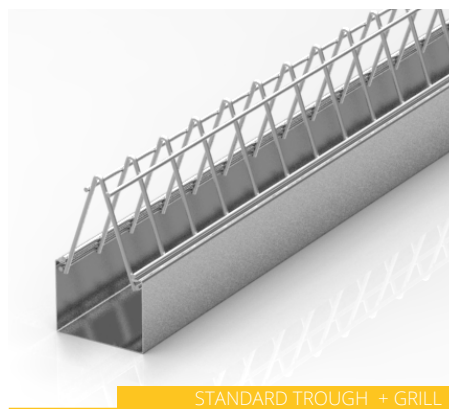

STANDARD TROUGH + GRILL

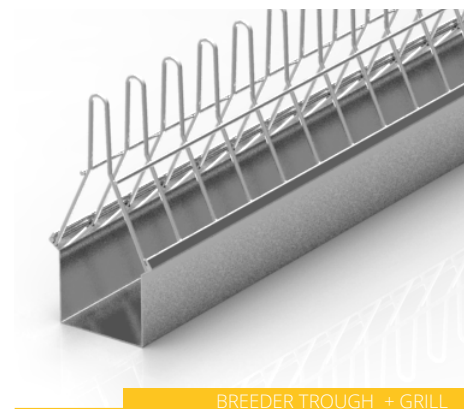

BREEDER TROUGH + GRILL

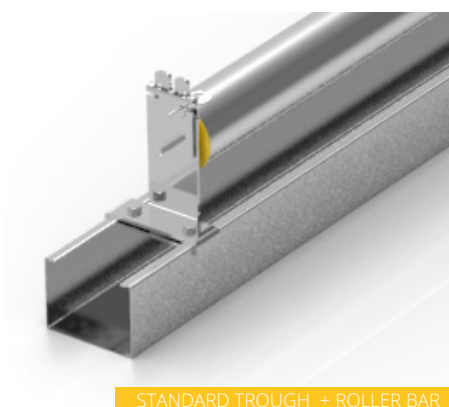

STANDARD TROUGH + ROLLER BAR

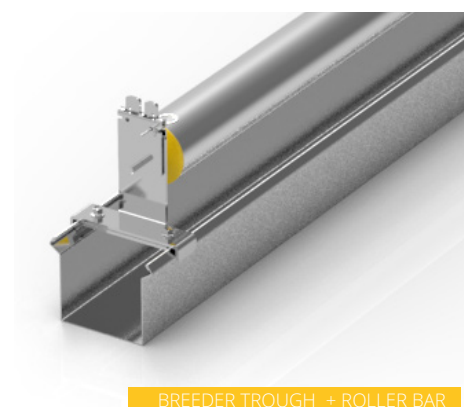

BREEDER TROUGH + ROLLER BAR

TECHNICAL SPECIFICATIONS

TECHNICAL DATA - SPIN FEEDER

Feed hopper	From 45 liters up to 750 liters (11.8877 gal – 198.1290 gal)
Capacity	Adjustable, max. 60 kg/min 132.2774 lb/min)
Distribution	Adjustable, max. 20 m (65.6168 ft)
Weight (without hopper)	19 kg (41.8878 lb)
Standard motor	0,55 kW (3-phase), 900 r/min rpm
Variator gear motor	0,25 kW (3-phase), 50-900 r/min rpm

TECHNICAL DATA - MALE FEEDING

Gear motor	1,5 kW (3-phase)
Chain speed	40 or 60 m/min (131.23 ft/min or 196.85 ft/min)
Total length	Max. 90 m (295.28 ft)
No. of males per meter trough	10-11, with access from both sides
Feed hopper	140 liters (36.9841 gal)

TECHNICAL DATA - FEMALE FEEDING

Gear motor	From 1,1 kW up to 1,5 kW (3-phase)
Chain speed	30 m/min or 40 m/min (98.4252 ft/min or 131.23 ft/min)
Feed hopper	1x140 liters, (36.9841 gal) 2x140 liters (2*36.9841 gal), 1x640 liters (double hopper) (169.0701 gal)
Length with four corners	Max. 200 m (656.17 ft) with 1 drive unit. Max 300 m (984.25 ft) with 2 drive units.

Standard trough

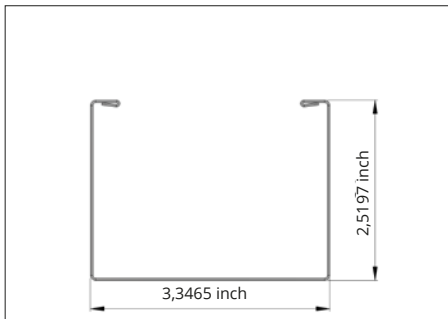

Breeder trough

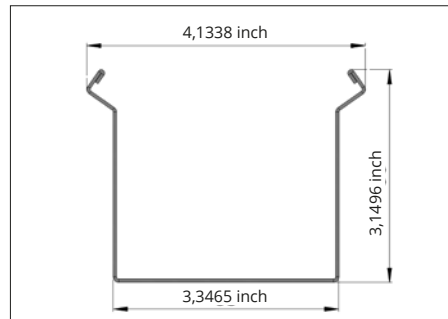

Feed inlet - stepwise adjustable

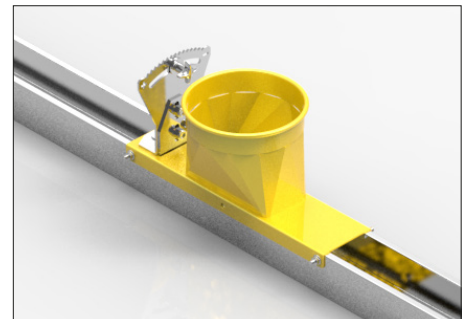

Hanging bracket



Reinforcement of corners

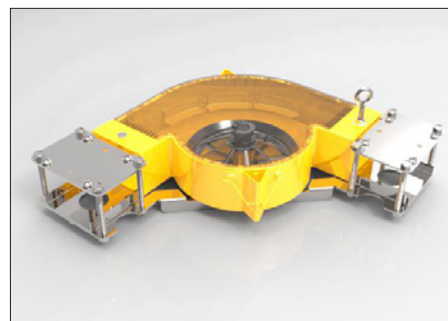

Direct drive

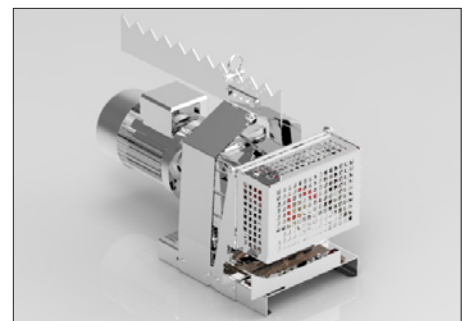

DEALER