

# A

## AUGERS





# AUGERS

## Wide range

LANDMECO offers a very wide auger range. The augers are built from standard components that can be combined and used for various auger sizes.

This makes it very simple to design precisely the right auger for specific tasks.

# FLEX AUGERS

## Inlet & outlet

Both the auger inlet and the outlet beside the geared motor are made of all-welded galvanized steel. Both can be mounted on the flex auger in precisely the direction required for the specific task. At the inlet, the auger is guided by a powerful ball bearing. Depending on the material to be transported, a limiting shaft can be built into the auger to prevent overloading. Both inlet and outlet are equipped with OK 160 mm (6.2992 inch) connection, ensuring easy connection to other equipment. Additional inlets and outlets can be fitted as required.

## Installing flex augers

As standard, all casings, both straight and curved, are supplied with a connector attached to one end. If these fitted connectors are not suitable, loose connectors are also available. Pipes are joined using stainless clamps.

*The geared motor is an integrated unit with closed oil bath gear. It requires a minimum of maintenance and ensures a long lifetime.*



Geared motor:

LANDMECO flex augers are the most flexible solution for transporting loose material whether it be feed, grain or wood pellets. The auger pipe is made of white, durable plastic, which provides the pipe with a smooth, long-lasting inner surface. Least possible friction is thus ensured.

The hardened spiral of flat spring steel is designed to ensure least possible damage to the material during transport while at the same time maximizing auger capacity. The pipe and inlet are completely sealed, thus ensuring that the material is effectively protected against the surrounding environment during transport. Augers can therefore be installed outdoors, either suspended above ground or buried in underground channels, without problems.



# FLEX AUGERS

## Capacity

It is highly variable, and depends on the material to be transported, auger pitch and choice of spiral.

Usually, the following applies:

A 75 mm (2.95 inch) auger casing has a capacity of 1100-1500 kg (2425-3306 lb) per hour. Max. pellet diameter is 8 mm. (0.31 inch)

A 90 mm (3.54 inch) auger casing has a capacity of 2000-2400 kg (4409-5291 lb) per hour. Max. pellet diameter is 10 mm. (0.39 inch)



## ACCESSORIES

LANDMECO FLEX AUGER DESIGN ALLOWS THE INSTALLATION OF EXTREMELY LONG AUGERS, AND IN EXTREME CASES THESE CAN BE CONNECTED TO ADDITIONAL AUGERS FOR CONTINUED TRANSPORT.

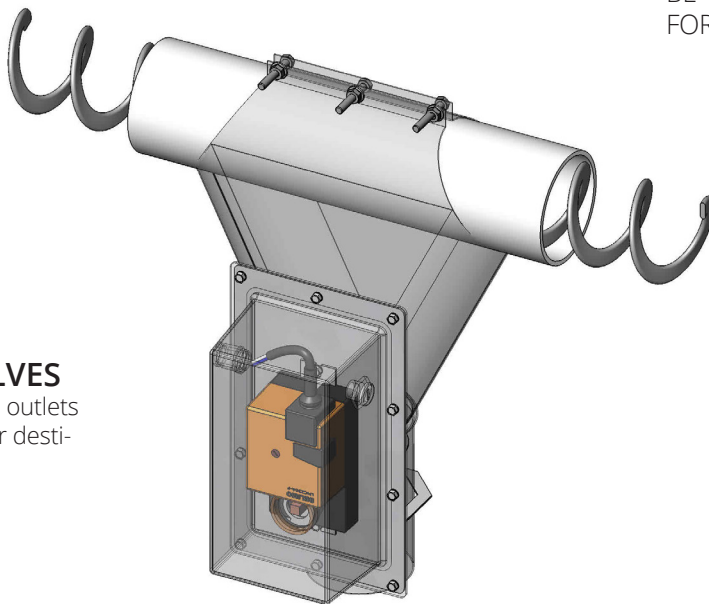

## ELECTRICAL VALVES

LANDMECO also offers outlets with electrical valves for destination feeding.



The wide range of outlets for LANDMECO flex augers is designed to meet all possible requirements (see back page).

# TECHNICAL SPECIFICATIONS

Flex spiral, 75 mm (2.95 inch)	Diam. 60x40x36 mm, (2.36x1.57x1.42 inch) 4,3x11,7 mm (0.17x0.46 inch) special steel
Flex spiral, 90 mm (3.54 inch)	Diam. 75x53x47 mm, (2.9x2.08x1.85 inch) 4,3x14,0 mm (0.17x0.55 inch) special steel
Flex spiral, 110 mm (4.33 inch)	Diam. 86x60x58 mm, (3.38x2.36x2.28 inch) 4,3x14,0 mm (0.17x0.55 inch) special steel
Auger pipe, 75 mm (2.95 inch)	Wall thickness 3.6 mm (0.14 inch)
Auger pipe, 90 mm (3.54 inch)	Wall thickness 4.0 mm (0.158 inch)
Auger pipe, 110 mm (4.33 inch)	Wall thickness 5,6 mm (0.22 inch)
Elbow, 75 mm (2.95 inch)	Wall thickness 3.6 mm, (0.14 inch) 60°
Elbow, 90 mm (3.54 inch)	Wall thickness 4.3 mm, (0.17 inch) 60°
Elbow, 110 mm (4.33 inch)	Wall thickness 5,3 mm, (0.2087 inch) 60°
Geared motor	1.1 kW (3x380V), 1400/300 rpm

1. Outlet, plastic, 75/90 mm. (2.95/3.54 inch)
2. Reduction adapter, OK 160-75 mm, (6.29-2.95 inch) single/double two-way.
3. Attachable outlet, OK 160 mm. (6.29 inch)
4. Attachable outlet, 74 mm, (2.91 inch) with PG

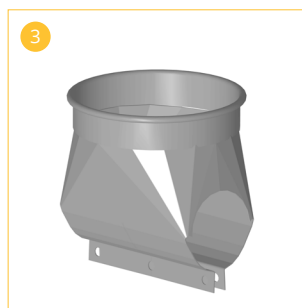

See also LANDMECO brochures on, for example:  
(LANDMECO retains the right to alter specifications without notice)



PAN FEEDING  
KICK-OFF 330°

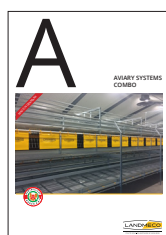

AVIARY SYSTEMS -  
COMBO



BREEDER FEEDING

## DEALER